

PART-1 GENERAL

**MAXIMUM CEILING HEIGHT 8'-0"
MINIMUM CEILING HEIGHT 7'-6"**

1.01 DESCRIPTION

- A. Plastic compartment work includes the following:
 - 1. Ceiling Hung partitions.
- B. Furnish all labor and materials necessary for the completion of work in this section as shown on the contract drawings and specified herein.
- C. Work in this section shall include, but is not limited to:
 - 1. Toilet compartments.
 - 2. Hardware for toilet compartments and plastic partitions.
 - 3. Shop drawings and working drawings.
 - 4. Manufacturer's guarantee.
- D. Related work specified elsewhere shall include accessories and anchorage/blocking for attachment of compartments.

1.02 PRODUCTS

- A. Submit six sets of shop drawings and details for architect's approval.
- B. Colors shall be selected from the manufacturer's standard range of colors.
- C. Color and hardware samples shall be submitted for approval to the architect upon request.

PART-2 PRODUCTS

2.01 MANUFACTURER

- A. Toilet compartments to be supplied by Global Partitions, Eastanollee, GA 30538.

2.02 MATERIALS

- A. Doors, panels and pilasters to be 1" thick with homogeneous color throughout, constructed from high density polyethylene (HDPE) resins, which are, waterproof non-absorbent and have a self-lubricating surface that resists markings from pens, pencils and other writing instruments.

2.03 CONSTRUCTION

- A. Doors, panels and pilasters shall be 1" thick with uniformly machined edges.
- B. Doors and panels shall be 55" high and mounted at 14" above the finished floor.
- C. Doors and panels to have an extruded aluminum heat sink strip attached to the lower edge.
- D. Pilasters shall be ceiling anchored. Pilasters shall include a mounting system comprised of 1/4" x 1" stainless steel mounting bar attached to the pilaster in a GLOBAL PLUG LOC arrangement, having 3/8" zinc plated steel bolts secured to 1/8" thick semi cylindrical PLUG LOC imbedded within a contoured aperture transversely piercing the core. Each mounting bar shall be secured to the building structure with 3/8" zinc plated steel studs. Cross bracing shall be 4" wide x 1" thick x appropriate length polymer (HDPE). A shoe shall conceal each ceiling mounting, having an internal cross section conforming to the pilaster.

2.04 HARDWARE (Note: Refer to the ORDER INFORMATION CONTRACT for the specific hardware to be supplied on your order.)

- A. Door hardware shall be as noted:
 - 1. Heavy-duty 8" aluminum hinge shall have gravity-acting cam. Slide latch, strike/keeper and hinges are through bolted onto doors and pilasters using stainless steel, vandal-resistant through bolts. Keeper provides for emergency access into the stall by lifting up on the bottom of the door.
 - 2. Optional: Heavy-duty diecast (vault) zamac hinge shall have gravity-acting cams and are fabricated from a die cast aluminum alloy with a brushed finish and wrap around flanges. The cam is constructed from a 3/4" diameter nylon rod and a 3/8" stainless steel pin. Slide latch, strike/keeper and hinges are through-bolted onto doors and pilasters using stainless steel vandal-resistant through bolts. Hinges are easily adjusted at the jobsite to a full close or partially open position, as required. Keeper provides for emergency access into the stall by lifting up on the bottom of the door.
 - 3. Optional: Continuous stainless steel hinge. Slide latch, strike/keeper and hinges are through bolted onto doors and pilasters using stainless steel, vandal-resistant through bolts.
- B. Panel and pilaster brackets shall be as noted:
 - 1. Aluminum stirrup brackets shall be 2" long made of heavy-duty anodized extruded aluminum (6063-T5 Alloy). Stirrup brackets shall be 1/8" thick and mounted with stainless steel, vandal-resistant screws. Panels shall be attached with stainless steel, vandal-resistant through bolts. The attachment of brackets to the adjacent wall construction shall be accomplished with 2 1/2" stainless steel vandal-resistant screws and plastic anchors.
 - 2. Optional: Continuous heavy duty anodized extruded aluminum (6063-T5 alloy) wall brackets are pre-drilled. Wall brackets are mounted with stainless steel, vandal-resistant screws. The attachment of brackets to the adjacent wall construction shall be accomplished with 2 1/2" stainless steel vandal resistant screws and plastic anchors.
 - 3. Optional: Continuous heavy duty stainless steel wall brackets are pre-drilled. Wall brackets are mounted with stainless steel, vandal-resistant screws. The attachment of brackets to the adjacent wall construction shall be accomplished with 2 1/2" stainless steel vandal resistant screws and plastic anchors.
 - 4. Optional: Continuous heavy duty PVC wall brackets are pre-drilled. Wall brackets are mounted with stainless steel, vandal-resistant screws. The attachment of brackets to the adjacent wall construction shall be accomplished with 2 1/2" stainless steel vandal resistant screws and plastic anchors.
- C. Pilaster shoes shall be stainless steel 5" high with a #4 satin finish. Pilaster shoes are anchored to the pilaster with #10 stainless steel, vandal-resistant screws. Optional: Plastic pilaster shoes shall be 5" high.

PART-3 EXECUTION

3.01 PREPARATION

- A. Examine areas to receive toilet compartments for correct height and spacing of anchorage/blocking and plumbing fixtures that may affect installation of compartments. Report any discrepancies to the architect.
- B. Take complete and accurate measurements of toilet compartment locations.
- C. Start of work constitutes acceptance of job.

3.02 INSTALLATION

- A. Install compartments in a rigid, straight, plumb and level manner, with steel laid out as shown on the shop drawings and manufacturer's installation instructions.
- B. All doors and panels to be mounted at 14" above the finished floor.

3.05

**MAXIMUM CEILING HEIGHT 8'-0"
MINIMUM CEILING HEIGHT 7'-6"**

- C. Clearance at vertical edges of door shall be uniform top to bottom.
- D. No evidence of cutting, drilling and/or patching shall be visible on the finished work.
- E. Finished surfaces shall be cleaned after installation and be left free of all imperfections.

3.03 WARRANTY

- A. GLOBAL Partitions guarantees its plastic against breakage, corrosion and delamination for 15 years from the date of receipt by the customer. If materials are found defective during that period for the reasons listed above, the materials will be replaced free of charge. No credits or allowances will be issued for any labor or expenses relating to the replacement of components covered under the warranty plan. All such expenses are to be borne by the buyer.

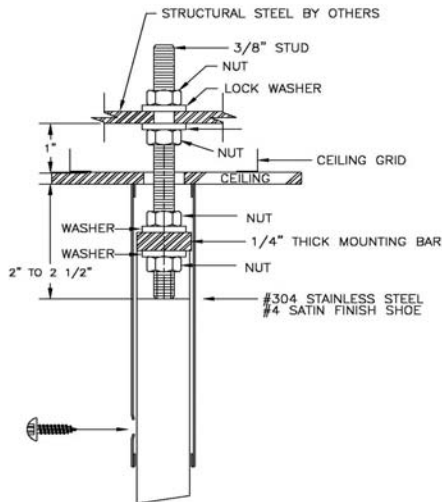
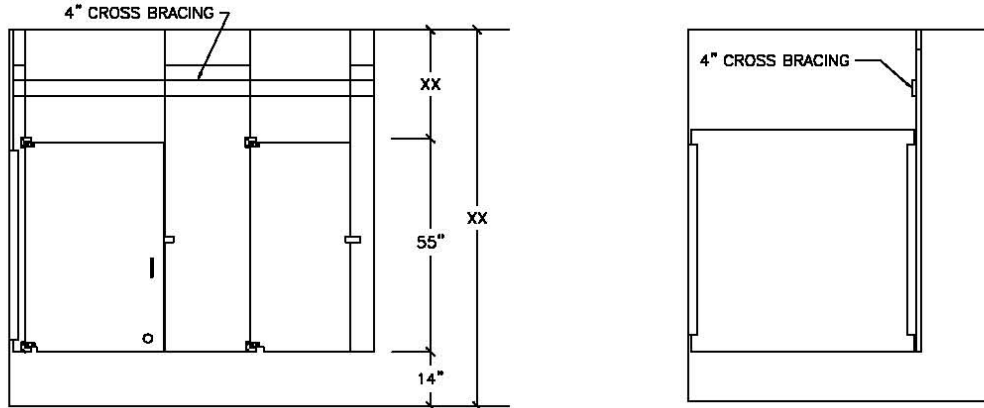

CEILING BOLT MOUNTING DETAIL

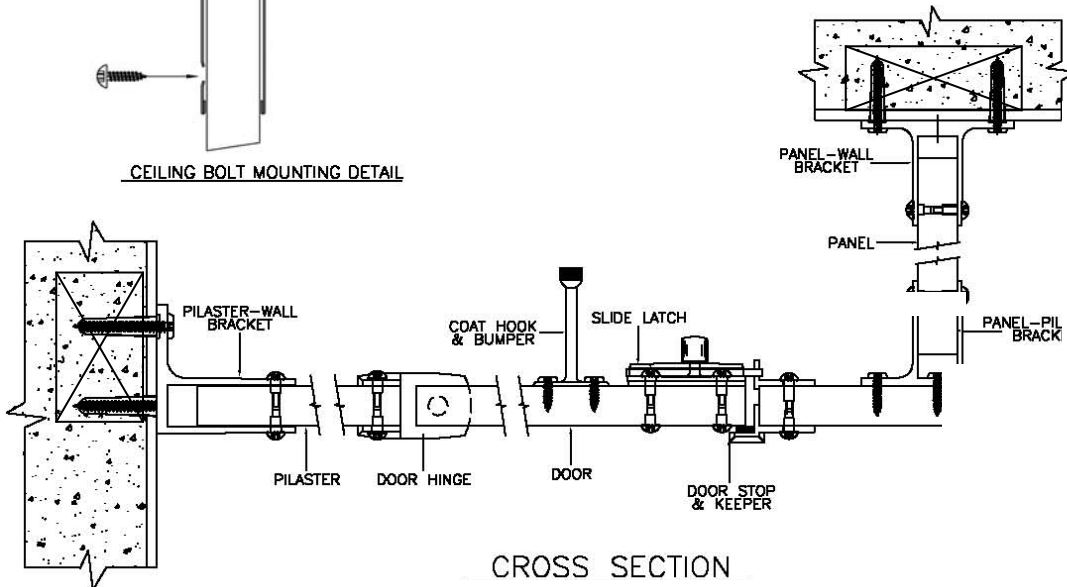

**CROSS SECTION
BLOCKING BY OTHERS**

3.06

.052010